



# ENVIROMESH

Garner Street Business Park, Etruria, Stoke-on-Trent, Staffordshire, ST4 7BH

Tel: +44 (0)845 136 0101 Fax: +44 (0)845 136 0202

[www.enviromeshgabions.com](http://www.enviromeshgabions.com)

## INSTALLATION GUIDE FOR STANDARD WELDED MESH GABION 39 SYSTEM

### JOINTING

**LACING WIRE** : Supplied as standard on gabion units for all joints.

Adjacent panels are joined together by a continuous lacing wire, weaving in and out of each mesh. As the wire is weaved in and out of the mesh it is pulled in the direction of weaving which then forms a tight joint.

All verticals joints and horizontal joints are to be laced. At the start and finish of the run of lacing, the wire should be wrapped around the panel wires 3 times.

It is recommended that the maximum length to be laced is approximately 1m. This requires about 1.4m of wire. The large coils of lacing wire supplied can be cut on one side of the coil which should give sufficient length for 1m of lacing. **Do not cut all coils, as longer lengths of wire are needed for internal bracing.**

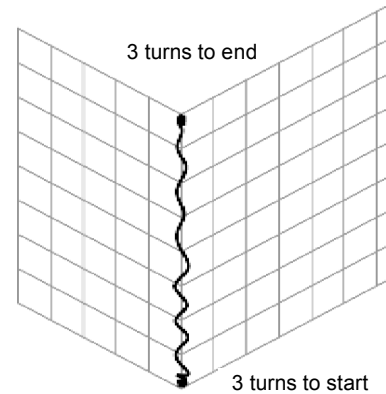

**HELICALS** : Supplied as standard on gabion 27 system units for vertical joints and with lacing wire for horizontal joints. Helicals are available at an additional cost for standard gabion 39 system. Please enquire with Enviromesh.

Adjacent panels are joined together by winding the helical down the mesh. Only use one helical for assembly when jointing to an adjacent unit.

At the top and bottom end of the helical, the last coil must be turned vertically through 90 degrees to prevent the helical from moving.

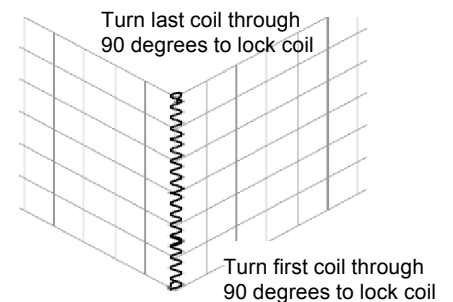

**'C' RINGS** : Supplied at an additional cost to gabion 27 or gabion 39 system. They can be used for all jointing of units.

'C' rings are closed with a pneumatic closing tool. The pneumatic tool has to be purchased and therefore is mainly used only on larger schemes.

'C' rings must be fixed every other mesh space on all joints.

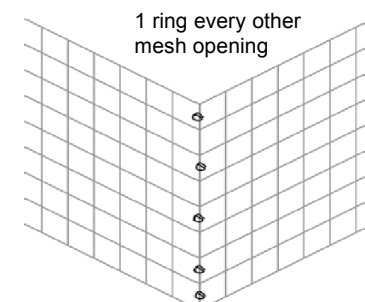

## **ASSEMBLY AND INSTALLATION:**

Units are supplied flat packed.

Open out unit flat (FIG 1).

Rotate front, back, ends and diaphragms vertically and joint using one of the methods of jointing described overleaf (FIG 2).

Note : If helicals are used, assemble internal joints only. All side panel joints are formed with the joint to the adjacent unit with one helical per joint.

Set assembled units in position to the correct line, level and inclination as required by the design and form joint to the adjacent units vertically. Where the units are coursed horizontally, joint to the unit below (FIG 3).

Machine fill the gabion unit with the correctly graded rock type as outlined in the specification to 1/3rd the unit height for 1m deep units and 1/2 the unit height for 0.5m deep units. Fill a series of cells in a run. If large voids are visible within the cell, re-orientate the rock to minimise the voids. If a hand-packed face is required, then when placing rock to the cells, load to the back of the cell first, then hand pick the rock for the facing and stack to achieve a dry stone wall appearance on the face.

Install internal windlass bracing ties central to each cell on the faces (spanning 2 meshes) (FIG 4) or alternatively if corner ties are supplied, then position a tie at each corner of the unit on the face and rear cells. Hook the tie, 4 meshes in from the corner around a mesh intersection on the face and rear panels, then wrap the free end around to secure (FIG 5 and 6). Diagonally brace to the side panels 4 meshes back and rotate the free end around a mesh joint intersection and wrap around to secure.

Note : Corner ties are standard on gabion 27 system and are available at additional cost on standard gabion 39 system.

On 1m deep units, fill the next 1/3 layer with rock and install another set of internal bracing.

Repeat filling to full height of unit in layers and then close the lid down by jointing to all horizontal joints with lacing wire ensuring the mesh bears down on the rock fill.

Should bulging of the face occur, then ensure the windlass bracing or corner ties are correctly installed. Loose or over-tightened ties will cause bulging to occur. Timbers or scaffold tubes can be temporarily wired to the face externally to act as a shuttering to prevent bulging and removed when filling is complete.

### **Note:**

If a run of units is not filled to each level in one go, then always step down the filling at the end otherwise unit distortion will occur. This also allows further units to be connected later (FIG 7).

At no time try to completely fill one cell at a time, unless the unit has internal bracing in both directions.

**FAILURE TO FOLLOW THE ABOVE INSTRUCTIONS MAY RESULT IN A POOR QUALITY INSTALLATION THAT IS NOT ACCEPTABLE TO THE CLIENT AND MAY BE STRUCTURALLY UNSOUND.**

**As well as following your own procedures for health and safety, it is essential when handling wire products that protective glasses and gloves are worn.**

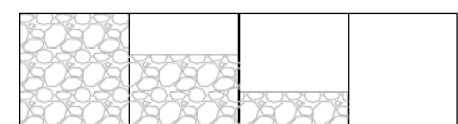
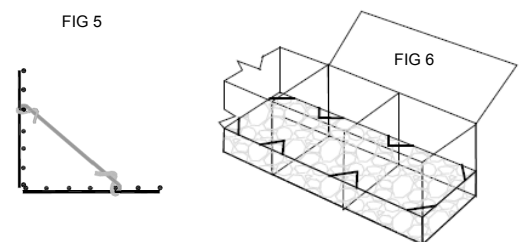
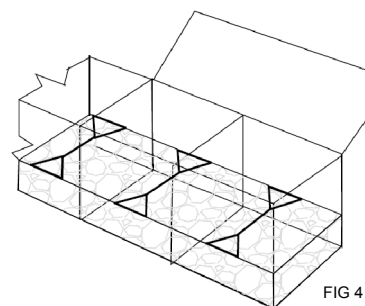
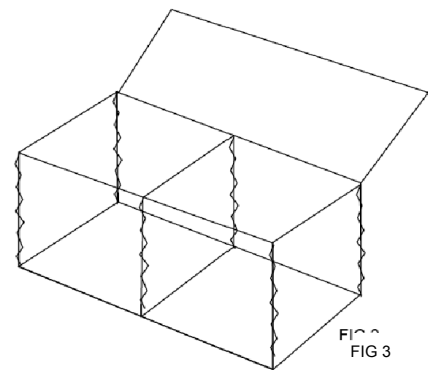
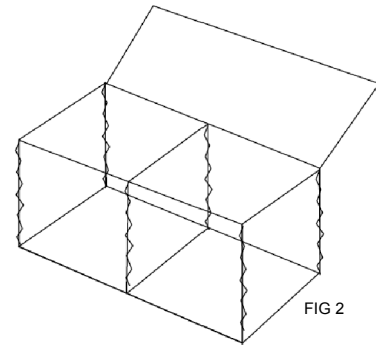
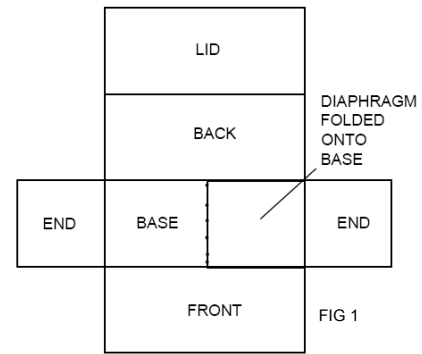

FIG 7